

MICROMAC HARDNESS

ON LINE ANALYZER FOR HARDNESS MONITORING IN WATER



MICROMAC HARDNESS is a microprocessor controlled On Line analyzer specifically designed for automatic Hardness monitoring on several types of water matrices.

✓ ROBUST AND RELIABLE

Designed for industrial and Environmental On Line applications ensures the highest level of robustness in the electronics, mechanics and hydraulics components. Complete separation between electronics and hydraulics plus a simple and robust LFA* hydraulics allows easy maintenance and long terms reliable operations.

**LFA: Loop Flow Analysis patent pending*

✓ EASY TO INSTALL

The analyzer is delivered after a long and successful series of factory tests ready for installation and setup; it is provided with complete set of spares for start up. To start monitoring is enough to connect reagents, sample line, waste line and power supply.

✓ AUTOMATIC CALIBRATION

When the Calibration Time interval expires the analyzer performs a Calibration Cycle, storing and checking the new calibrant O. D. If new O.D. exceeds selected limits, an alarm contacts is closed.

✓ SAMPLE DILUTION

Sample can be analyzed as it is or after automatic dilution. Automatic dilution is factory adjusted for high range applications.

✓ MEASURING INTERVAL

User selectable; between two measurements the analyzer remains in stand by mode, without reagents consumption.

✓ FEATURES AND BENEFITS

- Fully automatic operation
- Long autonomy; low maintenance, low operating cost
- Low reagents consumption; short preparation time; low disposable costs
- Easy operation; plug in analyzer, no special training is required
- Electronics and hydraulics completely separated
- Serial interface for local o remote PC connection (option)

Hardness measuring principle and hydraulic diagram

This automated method is an adaptation of the one outlined in Standards methods book.

After proper filtration, the sample is pumped inside the LFA reactor, where Mg/EDTA is added to bound the Ca ions present and release Mg ions. Then calmagite complex at pH 10 is added, that reacts with magnesium ions present in the sample plus the ones released by the Mg/EDTA complex; the formed purple red complex is measured colorimetrically at 525 nm.

The sample concentration is calculated against the calibration factor stored in the analyzer.

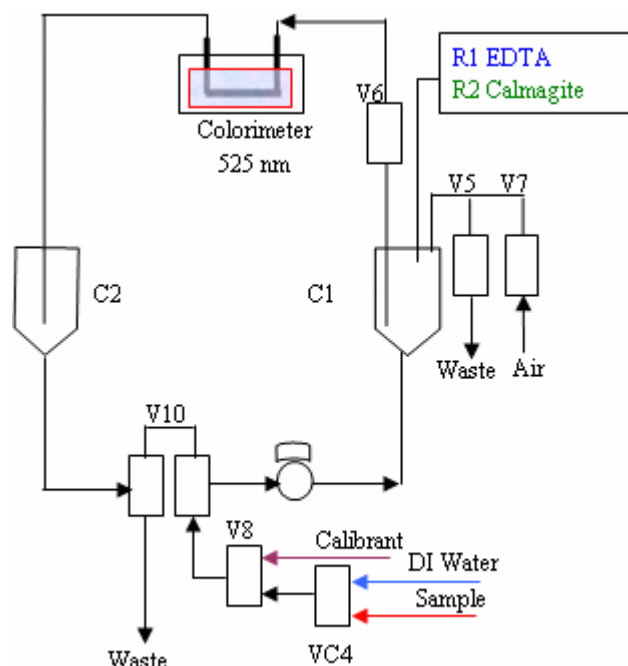

Technical Specifications

- MEASURING PRINCIPLE:** Colorimetric, Mg/EDTA, Calmagite
- COLORIMETER:** dual beam, silicon detector
- MEASUREMENT TYPE:** cyclic
- MEASURING INTERVAL:** programmable
- MEASURING TIME:** 10-12 minutes depending on the range
- MEASURING RANGE:** 0-1 up to 50°F, other ranges available on request
- DETECTION LIMIT:** typically better 2% of the full scale, calculated as for EPA p. 136 appendix B
- REPEATABILITY:** better than 2%
- OUTPUT SIGNAL:** 4-20 mA
- INPUT SIGNALS:** n. 1 Analysis, n. 1 calibration; digital contacts
- ALARMS:** n. 1 High Limit, n. 1 General, n. 1 Calibration; potential free contacts
- SAMPLE AND WASTE DELIVERY:** pressure free;
- SAMPLE TEMPERATURE:** 10 °C - 30 °C
- REAGENTS REPLACEMENT:** 3/4 weeks depending on the operating temperature
- PROTECTION:** IP55
- HARDWARE:** PC104 industrial standard, Integrated keyboard and graphics display, RS232 option
- POWER SUPPLY:** 12 V DC external power supply included; 4W Standby; 10 W (mean) analysis
- WEIGHT:** 33 Kg without reagents;
- DIMENSION:** 800x450x300 mm (hwxwd)

Subject to change without notice



SYSTEA S.p.A.
 HEADQUARTER AND MANUFACTURING FACILITY:
 VIA PADUNI, 2A - 03012 ANAGNI (FR) ITALY
 TEL: +39 0775-776058 FAX +39 0775-772204
A member of Consorzio NDI

Web Site: <http://www.systea.it> Email: info@systea.it

Document ID: MicC_Hardness-02-E